

Coil Lifters and Upenders

Model 83E – Ergonomic Vertical “Eye” Coil Lifter



NEW

PRODUCT FEATURES:

- Efficient handling of vertically stacked coils.
- Handles coils with ID's of 16", 20", and 24".
- Ergonomic handles and guide.
- Horizontal handle with pin lever is easy to actuate.
- Spring loaded lever can be set for right- or left-handed operation.
- Unique 360° guide handle is easily accessed from any location.
- Optimized foot accommodates 5/8" blocking
- Complies with ASME standards.

QUICKSHIP PROGRAM

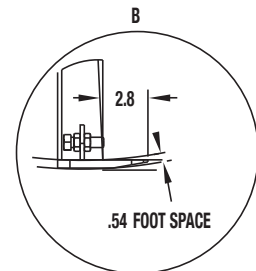
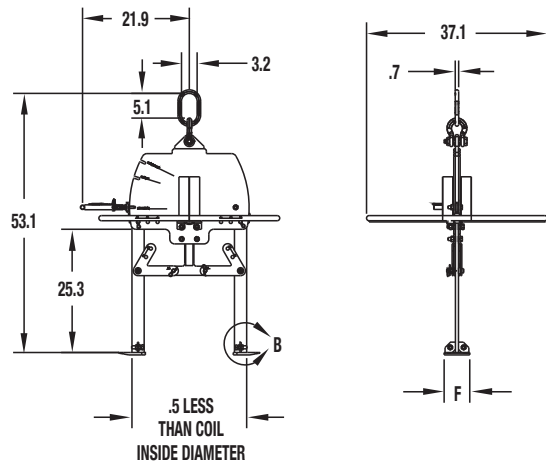
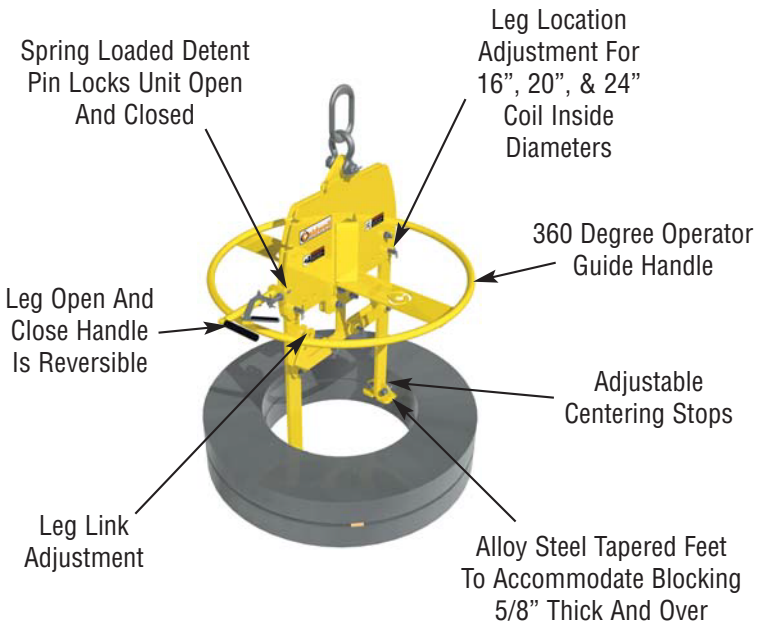

SPECIFICATIONS

Model Number	Rated Capacity (tons)	F (in.)	Weight (lbs.)
83E-3-16/20/24	3	5.3	160
83E-5-16/20/24	5	8	165