

Coil Lifters and Upenders

Model 85 – Fixed Bail Telescoping Coil Grab



PRODUCT FEATURES:

- Motorized leg drive maximizes the efficient handling of coils.
- Leg drive speed - 2.8" per second.
- Narrow aisle stacking maximizes coil storage floor space.
- Curved lifting pads for coil protection.
- High impact plastic toe rollers prevent lifter foot contact.
- Anti-clamp limit switch protects coil during closing of lifter.
- Heavy duty torque limiting drive protection during maximum open/closed conditions.
- Lockout limit switch prevents inadvertent leg opening during lift.
- Alloy steel pin bail.
- Easily replaceable slide wear guides.
- Design allows for easy maintenance access to drive components.
- Designed to operate on AC power supply.
- Field upgradeable to rotating style.
- Complies with ASME standards.

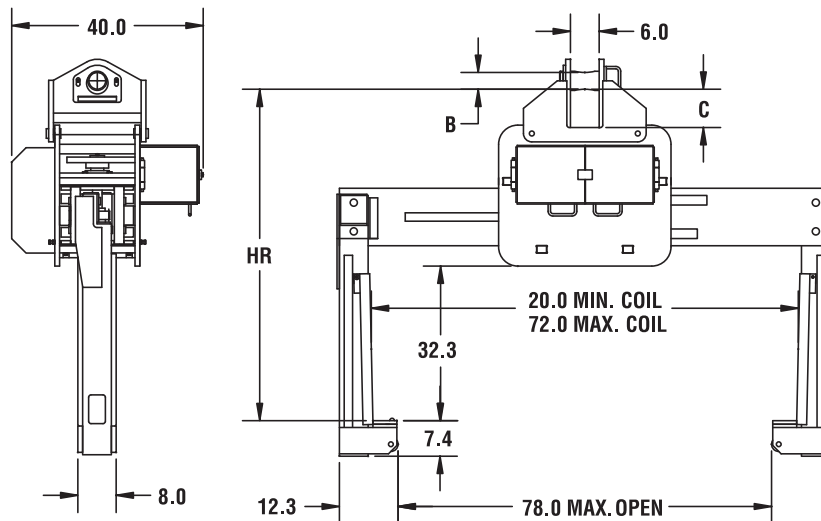

Outside width at 20" minimum coil dimension is 79-1/2".

NOTE: Dimensions shown in inches.

SPECIFICATIONS

Model Number	Capacity (tons)	Dimensions (inches)						Weight (lbs.)
		Coil Width		HR Headroom	Throat	Pin/Bail		
		Min.	Max.			B	C	
85-15-72	15	20	72	67-1/2	32.3	3	8-1/4	3440
85-20-72	20	20	72	67-1/2	32.3	3	8-1/4	3540
85-25-72	25	20	72	69-1/4	32.3	3-1/2	8	3780
85-33-72	33	20	72	69-1/4	32.3	3-1/2	8	3880

Other sizes available, consult factory.